

DRAW-TITE® CUSTOM BUILT TRAILER HITCHES

DRAW-TITE GIVES YOU TOP QUALITY IN EVERY HITCH AND RECEIVER WE MAKE:

- Solid all-welded construction for maximum strength and safety.
- Custom built according to manufacturer vehicle weight specifications and model year to ensure perfect fit and top towing performance.
- All Draw-Tite hitches meet and exceed V-5 and SAE J684 standards and are inspected for quality and workmanship.
- Computer-aided design and fatigue stress testing ensure a strong design that will withstand road abuse within specified capacities.
- Finish is black powder coat over e-coat (industry leading corrosion resistance).
- Backed by a nationwide limited lifetime warranty.

SELECTING THE RIGHT HITCH

- Determine the Gross Trailer Weight and Gross Tongue Weight of the trailer that you would like to tow. Check with the trailer manufacturer or if you are not sure, have it towed to a government inspection scale. Remember that the G.T.W. should reflect a fully loaded trailer.
- Consult your vehicle’s owner’s manual to determine if your vehicle is rated to safely tow your trailer.
- Use the chart to figure out the minimum “Class” of hitch that is required.
- Consult a Draw-Tite dealer to find out which hitches are available for your vehicle. Or visit our website: www.draw-tite.com.

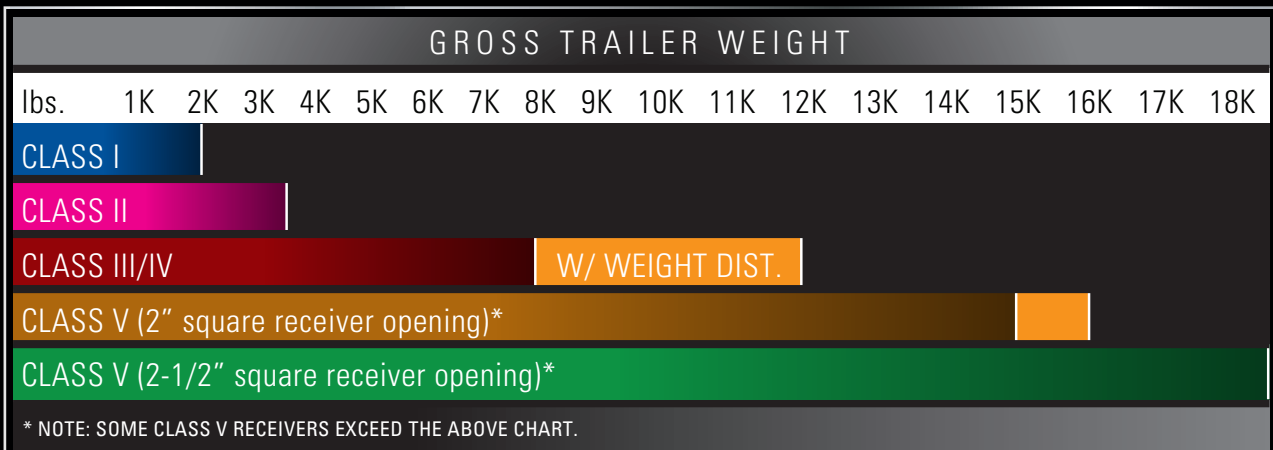

RECEIVER HITCHES

RECEIVER HITCHES

- Draw-Tite® Receiver Hitches - Class I / II
- Draw-Tite® Receiver Hitches - Class III / IV
- Draw-Tite® Receiver Hitches - Class V Ultra Frame®
- Draw-Tite® Receiver Hitches - Class V Ultra Frame® with Cast Center Section
- Hidden Hitch® Receiver Hitches - Class I / II
- Hidden Hitch® Receiver Hitches - Class III / IV
- Reese® Receiver Hitches - Class III / IV
- Reese® Receiver Hitches - Class V Titan®
- Reese® Receiver Hitches - Super Titan®
- Pro Series™ Receiver Hitches - Class I / II
- Pro Series™ Receiver Hitches - Class III / IV

ULTRA FRAME® CLASS V RECEIVER HITCHES

- Ultra Frame® Class V Receiver Hitches
- Ultra Frame® Class V Receiver Hitches with Cast Center Section
- Ultra Frame® Ball Mounts
- Ultra Frame® Hitch Balls
- Ultra Frame® Trunnion Style Weight Distribution
- Ultra Frame® Work Truck Hitch

TITAN® CLASS V RECEIVER HITCHES

- Titan® Class V Receiver Hitches
- Titan® Ball Mounts
- Titan® Hitch Balls
- Titan® Receiver Extensions / Reducer Sleeve
- Titan® Trunnion Style Weight Distribution

SUPER TITAN® RECEIVER HITCHES

- Super Titan® Receiver Hitches
- Super Titan® Ball Mounts with Hitch Balls
- Super Titan® Accessories
- Super Titan® Pintle Hook Mount

MOTORHOME HITCHES

- Multi-Fit Motorhome Hitches
- Universal Motorhome Hitches
- Motorhome Class III Receiver Hitches
- Step Bumper Hitches
- Class III Roll Pan Receiver Hitches

FRONT MOUNTED RECEIVERS / ACCESSORIES

- Front Mounted Receivers
- Front Mounted Receiver Accessories

HITCH ACCESSORIES

- Combo Bars
- Fasteners
- Safety Chain Loops





DRAW-TITE GIVES YOU TOP QUALITY IN EVERY HITCH AND RECEIVER WE MAKE:



- Solid all-welded construction for maximum strength and safety
- Custom built according to manufacturer & model year to ensure perfect fit and top towing performance
- Computer-aided design and fatigue stress testing ensure a strong design that will withstand road abuse within specified capacities
- All hitches meet or exceed V-5 and SAE J684 standards and are inspected for quality and workmanship
- Backed by a nationwide limited lifetime warranty
- Black powder coat finish over e-coat

CLASS I SPORTFRAME™ Part No. Series 24XXX



- 1-1/4" square receiver tube opening
- Economical Class I receiver style hitch
- Comes complete with removable drawbar, pin and clip
- Attaches to vehicle frame and/or bumper
- Black powder coat finish over e-coat

Description	Maximum Rated Capacity	
	Gross Trailer Wt.	Tongue Wt.
Weight Carrying	Up to 2,000 lbs.	Up to 200 lbs.

CLASS II FRAME HITCH™ Part No. Series 36XXX



- 1-1/4" square receiver tube opening
- Receiver style hitch with removable drawbar
- Comes complete with removable drawbar, pin and clip
- Neat appearance and all frame attachments
- Black powder coat finish over e-coat

Description	Maximum Rated Capacity	
	Gross Trailer Wt.	Tongue Wt.
Weight Carrying	Up to 3,500 lbs.	Up to 300 lbs.

**NOW YOU SEE IT,
NOW YOU DON'T!
ONCE INSTALLED THE
INVISIBLE HITCH IS
COMPLETELY HIDDEN
FROM VIEW!**



CLASS I/II INVISI-HITCH™ Part No. Series 285XX

- 1-1/4" square receiver tube opening
- One piece construction for a stronger hitch and easier installation
- Direct attachment allows hitch to be affixed well under vehicle for minimum visibility when drawbar is removed
- Includes mounting hardware and easy to read instructions
- Removable drawbar & accessory adapter sold separately
- Black powder coat finish over e-coat

Description	Maximum Rated Capacity	
	Gross Trailer Wt.	Tongue Wt.
Weight Carrying	Up to 3,500 lbs.	Up to 300 lbs.

28351
sold separately

28451
sold separately



New

HITCH / ACCESSORY - RATING GUIDE

Scan this barcode with your mobile phone to access:
www.cequentgroup.com/accessrating.asp



CLASS III/IV SQUARE & ROUND TUBE MAX-FRAME™ RECEIVERS Part No. Series 75XXX

- 2" square receiver tube opening
- Max-Frame receivers are designed for customers with trucks, vans and sport utility vehicles
- Designed for today's stylish sport utility vehicles, round tube receivers complement vehicle appearance
- All frame attachments
- Black powder coat finish over e-coat
- Ball mount, hitch ball, wiring and accessories sold separately
- J-Pin® ready
- 75XXX ball mounts #23 and #53 are available (Max-Frame Program)



Description	Maximum Rated Capacity	
	Gross Trailer Wt.	Tongue Wt.
Weight Carrying	Up to 8,000 lbs.	Up to 1,200 lbs.
Weight Distributing	Up to 12,000 lbs.	Up to 1,200 lbs.



CLASS III/IV MAX-E-LOADER™ RECEIVERS Part No. Series 41XXX

- 2" square receiver tube opening
- Max-E-Loader's long side bracket design distributes the towing load over a greater portion of the tow vehicle frame
- All frame attachments
- J-Pin® ready
- Black powder coat finish over e-coat

Description	Maximum Rated Capacity	
	Gross Trailer Wt.	Tongue Wt.
Weight Carrying	Up to 6,000 lbs.	Up to 600 lbs.
Weight Distributing	Up to 12,000 lbs.	Up to 1,200 lbs.



See page A-5 for accessories for the Ultra Frame Receivers

CLASS V ULTRA FRAME® RECEIVERS Part No. Series 419XX

- 2" square receiver tube opening
- Designed for full-size long wheelbase trucks, vans and utility vehicles with full frames and heavy-duty suspensions
- Ideal for high tongue weight applications (Example: Toy Hauler)
- Strong, secure heavy-duty side bracket design
- All frame attachments
- J-Pin® ready
- Black powder coat finish over e-coat
- **NEW!** Redesign of Ultra Frame® receivers to include Cast Center Section
 - New rugged appearance
 - Cast steel material
 - Bigger chain loops
 - Tighter ball mount fit
 - Reinforced pin hole



ULTRA FRAME® RECEIVERS With Cast Center Section



Description	Maximum Rated Capacity	
	Gross Trailer Wt.	Tongue Wt.
CLASS V ULTRA FRAME® RECEIVERS		
Weight Carrying	Up to 15,000 lbs.	Up to 1,500 lbs.
Weight Distributing	Up to 16,000 lbs.	Up to 1,600 lbs.
CLASS V ULTRA FRAME® RECEIVERS WITH CAST CENTER SECTION		
Weight Carrying	Up to 16,000 lbs.	Up to 2,400 lbs.
Weight Distributing	Up to 16,000 lbs.	Up to 1,600 lbs.

NOTE: Contact Customer Service for availability of new Cast Center Section part numbers



ULTRA FRAME® SOLID SHANK BALL MOUNTS



Part No.	Rating (lbs.) GTW/TW	Ball Hole Size	A Length	B Rise	C Drop	Style
4280	12,000/1,200	1-1/4"	8-1/2"	1"	2"	1
4284	12,000/1,200	1-1/4"	12"	1"	2"	1
4281	12,000/1,200	1-1/4"	8-1/2"	3"	4"	3
4285	12,000/1,200	1-1/4"	12"	3"	4"	3
4282	12,000/1,200	1-1/4"	9-1/2"	5"	6"	3
4283	12,000/1,200	1-1/4"	9-1/2"	7"	8"	3



All hitch balls designed with wrench flats

ULTRA FRAME® HITCH BALLS

Ball Dia. A	Finish		Shank Dia. B	Shank Length C	Drawbar Thickness Range	GTW GVWR Rating
	Zinc	Chrome				
2-5/16"	63835	63834	1-1/4"	2-3/4"	3/8"-1"	12,000
2-5/16"	-	63836	1-1/4"	2-3/4"	3/8"-1"	14,000
2-5/16"	-	63840	1-1/4"	2-3/4"	3/8"-1"	20,000

ULTRA FRAME® WEIGHT DISTRIBUTING TRUNNION STYLE

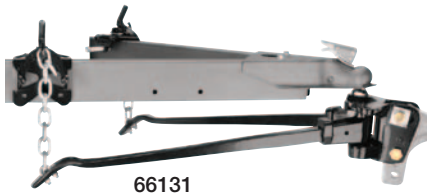

- Raised hitch ball platform eliminates the need for raised hitch balls
- Easy-to-use serrated washer
- Forged ball platform and spring bar mounts
- Rated up to 15,000 lbs. GTW / 1,500 lbs. TW

Part No.	Description	Gross Trailer Wt.	Tongue Wt.
66131	Weight Distributing Hitch	15,000 lbs.	1,500

Use Shank #63970 or #63971

See page A-4 for
Ultra Frame™ Receivers

ULTRA FRAME® WORK TRUCK HITCH

**MANUFACTURED FOR SERVICE BODY
& FLAT BED STAKE TRUCKS**



#41991 - 62" Center Section

MIX & MATCH CENTER SECTION AND SIDE BRACKETS

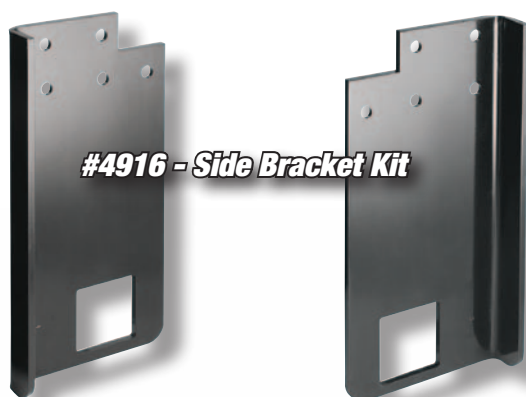

#4916 - Side Bracket Kit

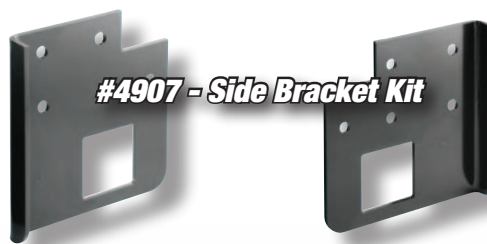

#4907 - Side Bracket Kit



**#58374 - End Caps
are also available**



#41990 - 44" Center Section

- **VERSATILE FOR VARIOUS MAKES AND MODELS**
- **FABRICATION KIT REQUIRES WELDING**
- **41991 SATISFIES DOT SEC. 393 .86 (B) (1)**

ULTRA FRAME® SERVICE BODY RECEIVERS

Part No.	Description	GTW	TW
41991-07	Includes 41991 (62") & 4907	16,000 lbs.	1,600 lbs.
41991-16	Includes 41991 (62") & 4916	16,000 lbs.	1,600 lbs.
41990-07	Includes 41990 (44") & 4907	16,000 lbs.	1,600 lbs.
41990-16	Includes 41990 (44") & 4916	16,000 lbs.	1,600 lbs.



HIDDEN HITCH - FEATURES AND BENEFITS



- Low profile design to compliment the rear contours and aerodynamic styling of today's vehicles
- Removable drawbars and ball mounts enhance the appearance of the vehicle when not in use
- Custom designed hitches are specific to vehicle type and model year for simple installation and superior fit
- Custom designed hitches reduce cutting of bumper and drilling
- All hitches meet or exceed V-5 and SAE J684 standards and are inspected for quality and workmanship
- Backed by a nationwide limited lifetime warranty
- Black powder coat finish over e-coat



CLASS I Part No. Series 6XXXX

- Sleek design built to enhance the rear contour of the vehicle in 1-1/4" square drawbar
- Comes complete with removable drawbar, pin and clip
- Hitch ball, wiring and accessories sold separately
- Contoured round tube design where appropriate

Description	Maximum Rated Capacity	
	Gross Trailer Wt.	Tongue Wt.
Weight Carrying	Up to 2,000 lbs.	Up to 200 lbs.



CLASS II Part No. Series 9XXXX

- 1-1/4" square receiver tube opening
- One piece construction for a stronger hitch and easier installation
- Direct attachment allows hitch to be affixed well under vehicle for minimum visibility when drawbar is removed
- Comes complete with removable drawbar, pin and clip
- Hitch ball, wiring and accessories sold separately

Description	Maximum Rated Capacity	
	Gross Trailer Wt.	Tongue Wt.
Weight Carrying	Up to 3,500 lbs.	Up to 300 lbs.

**NOW YOU SEE IT,
NOW YOU DON'T!
ONCE INSTALLED THE
INVISIBLE HITCH IS
COMPLETELY HIDDEN
FROM VIEW!**



CLASS I/II INVISI-HITCH™ Part No. Series 285XX

- 1-1/4" square receiver tube opening
- One piece construction for a stronger hitch and easier installation
- Direct attachment allows hitch to be affixed well under vehicle for minimum visibility when drawbar is removed
- Includes mounting hardware and easy to read instructions
- Drawbar, accessory adapter, hitch ball, wiring and accessories sold separately

Description	Maximum Rated Capacity	
	Gross Trailer Wt.	Tongue Wt.
Weight Carrying	Up to 3,500 lbs.	Up to 300 lbs.



28351
sold separately

28451
sold separately



CLASS III/IV SERIES Part No. Series 7XXXX, 825XX, 87XXX

- 2" square receiver tube opening
- Includes mounting hardware and easy to read instructions
- Ball mount sold separately on 825XX
- Ball mount, hitch ball, wiring and accessories sold separately
- J-Pin® ready (Only on new hitch designs)
- 7XXXX & 87XXX ball mounts #127 and #139 are available (Receiver Plus Program)

Description	Maximum Rated Capacity	
	Gross Trailer Wt.	Tongue Wt.
Weight Carrying	Up to 8,000 lbs.	Up to 1,200 lbs.
Weight Distributing	Up to 12,000 lbs.	Up to 1,200 lbs.



CLASS III/IV UNIVERSAL MULTI-FIT RECEIVER

- SHIPPED IN RETAIL CARTON
- Up to 6,000 lbs. / 600 lbs. WC - 10,000 lbs. / 1,000 lbs. WD
- Designed to fit a wide range of pick-up trucks
- Includes hitch receiver cover, mounting hardware and easy to read instructions
- Ball mount, hitch ball, wiring and accessories sold separately

Part No.	Description
82000	Class III/IV Multi-Fit Receiver



New
HITCH / ACCESSORY - RATING GUIDE
 Scan this barcode with your mobile phone to access:
www.cequentgroup.com/accessrating.asp

QUICK DEFINITIONS

GTW = Gross Trailer Weight ... Weight of the trailer fully loaded

TW = Tongue Weight ... Weight exerted by the trailer coupler on the hitch ball

WC = Weight Carrying ... Tow rating capacity of a hitch without a weight distributing system

WD = Weight Distributing ... Tow rating capacity of a hitch when using a weight distributing system



REESE GIVES YOU TOP QUALITY IN EVERY HITCH AND RECEIVER WE MAKE:



- Solid all-welded construction for maximum strength and safety
- Custom built according to manufacturer & model year to ensure perfect fit and top towing performance
- Computer-aided design and fatigue stress testing ensure a strong design that will withstand road abuse within specified capacities
- All hitches meet or exceed V-5 and SAE J684 standards and are inspected for quality and workmanship
- Backed by a nationwide limited lifetime warranty
- Black powder coat finish over e-coat

CLASS III/IV PROFESSIONAL RECEIVERS

Part No. Series 33XXX, 44XXX



- 2" square receiver tube opening
- Round tube designs available on some models
- Includes distinctive patented collar and plug
- Ball mount, pin & clip sold separately
- Many applications are "no drill" for fast and easy installation
- Black powder coat finish over e-coat



Description	Gross Trailer Wt.	Maximum Rated Capacity	
		Tongue Wt.	
Weight Carrying	Up to 8,000 lbs.	Up to 1,200 lbs.	
Weight Distributing	Up to 12,000 lbs.	Up to 1,200 lbs.	

CLASS III/IV PREMIUM RECEIVERS

Part No. Series 35XXX, 36XXX, 37XXX



- 2" square receiver tube opening
- Round tube designs available on some models
- Boxed for easy shipping
- Includes distinctive patented collar and plug
- Ball mount, pin & clip sold separately
- Designed for a great custom fit
- Many applications are "no drill" for fast and easy installation
- Black powder coat finish over e-coat

Description	Gross Trailer Wt.	Maximum Rated Capacity	
		Tongue Wt.	
Weight Carrying	Up to 7,500 lbs.	Up to 750 lbs.	
Weight Distributing	Up to 12,000 lbs.	Up to 1,200 lbs.	

QUICK DEFINITIONS

GTW = Gross Trailer Weight ... Weight of the trailer fully loaded

TW = Tongue Weight ... Weight exerted by the trailer coupler on the hitch ball

WC = Weight Carrying ... Tow rating capacity of a hitch without a weight distributing system

WD = Weight Distributing ... Tow rating capacity of a hitch when using a weight distributing system



CLASS III/IV MULTI-FIT RECEIVERS

Part No. 37034, 37051, 37069, 37152

- 2" square receiver tube opening
- 4 hitch models fit full-size pick-up trucks, SUVs and full-size vans, and light pick-up trucks
- 37034 & 37051 features a contemporary round tube design
- Boxed for easy shipping
- Includes distinctive patented collar and plug
- Ball mount, pin & clip sold separately
- Black powder coat finish over e-coat
- Limited 3 year warranty

Description	Maximum Rated Capacity	
	Gross Trailer Wt.	Tongue Wt.
Weight Carrying	Up to 7,000 lbs.	Up to 700 lbs.
Weight Distributing	Up to 12,000 lbs.	Up to 1,200 lbs.



See page A-11 for accessories for the Titan Receivers

CLASS V TITAN® RECEIVERS Part No. Series 45XXX

- 2-1/2" square receiver tube opening
- Designed for full-size long wheelbase trucks, vans and utility vehicles with full frames and heavy-duty suspensions
- Ideal for high tongue weight applications (Toy Hauler & Commercial)
- Strong, secure heavy-duty side bracket design
- All frame attachments
- Pin, clip and receiver tube cover included
- Welded electrical bracket included

Description	Maximum Rated Capacity	
	Gross Trailer Wt.	Tongue Wt.
Weight Carrying	Up to 18,000 lbs.	Up to 2,000 lbs.
Weight Distributing	Up to 18,000 lbs.	Up to 2,500 lbs.



New

HITCH / ACCESSORY - RATING GUIDE

Scan this barcode with your mobile phone to access:
www.cequentgroup.com/accessrating.asp



CLASS V TITAN® RECEIVERS Part No. Series 45XXX

- Large 2-1/2" square receiver opening allows for larger capabilities
- Designed for heavy duty use with 3/4 & 1-ton vehicles only
- Fits most full-size pickups and SUVs
- Designed to fit with standard factory step bumper
- Ideal for high tongue weight applications (Toy Hauler & Commercial)



45322

45122



45325



All hitch balls built with wrench flats



45292



58102

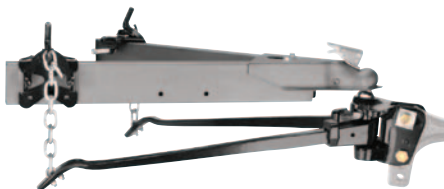

Description	Maximum Rated Capacity	
	Gross Trailer Wt.	Tongue Wt.
Weight Carrying	Up to 18,000 lbs.	Up to 2,000 lbs.
Weight Distributing	Up to 18,000 lbs.	Up to 2,500 lbs.

TITAN® BALL MOUNTS

- 2-1/2" square shank for use exclusively with Titan® receivers

Part No.	Rating (lbs.) GTW/TW	Ball Hole Size	A Length	B Rise	C Drop	Style
45122	14,000/1,400	1-1/4"	9-1/2"	1-1/2"	3"	3
45123	13,000/1,300	1-1/4"	10"	3-1/2"	5"	3
45291	13,000/1,300	1-1/4"	10-1/2"	-	7-3/4"	3
45322	18,000/2,000	1-1/4"	10"	1-1/2"	3"	3
45323	18,000/2,000	1-1/4"	10"	3-1/2"	5"	3

Part No.	Description	Rating (lbs.) GTW/TW	Shank Length	Ball Size
45325	Titan® Tri-Ball Mount, Hollow Shank, Black Balls	2,000/200 10,000/1,000 14,000/1,400	8-3/4"	1-7/8" 2" 2-5/16"

TITAN® HITCH BALLS

Ball Dia. A	Finish		Shank Dia. B	Shank Length C	Drawbar Thickness Range	GTW GVWR Rating
	Zinc	Chrome				
2-5/16"	-	63836	1-1/4"	2-3/4"	3/8"-1"	14,000
2-5/16"	-	63840	1-1/4"	2-3/4"	3/8"-1"	20,000

TITAN® RECEIVER EXTENSIONS

- Ideal for slide-out campers with extended overhangs
- 2" opening for use w/standard ball mounts & hitch-mounted accessories
- For use with Titan® receivers only
- Integrated electrical bracket attached

Part No.	Description	Length	WC(lbs.)	WD(lbs.)
45292	Receiver Extension	24"	6,000	8,000
		34"	4,500	6,000
45018	Receiver Extension	41"	5,000	7,500
		48"	4,000	6,000

TITAN® REDUCER SLEEVE

- Reduces 2-1/2" Titan® receiver to 2" opening for hitch-mounted accessories

Part No.	Description
58102	Titan® Reducer Sleeve from 2-1/2" to 2"

TITAN® WEIGHT DISTRIBUTING TRUNNION STYLE

- Trunnion style WD kit with integrated cams for use with Dual Cam Sway Control
- Perfect for use with horse trailers and RV's with **heavy tongue** weights, great for agricultural, marine and recreational use
- Adjustable hitch bar sold separately

Part No.	Description	Gross Trailer Wt.	Tongue Wt.
66006	Weight Distributing Hitch	17,000 lbs.	1,700

Use Shank #54976 or #54977



SUPER TITAN BALL MOUNT (INCLUDED)



SUPER TITAN® 4000 - 25K

- Large 3" square receiver opening
- Rated for 25,000 lbs. weight carry capacity; 4,000 lbs. tongue weight
- Dual stacked receiver tubes for proper height adjustments
- Two electrical plug and air brake hook up mounting locations for easy trailer attachments
- For frame widths from 34" to 34-1/2"
- Air brake fittings for easy trailer hookups
- 2-5/16" ball and ball mount included
- Pin & clip included

Note: 38124 is 14-1/2" from bottom of frame to bottom of dual stacked receiver tube Note: 38208 is 10-1/2" from bottom of frame to bottom of dual stacked receiver tube

Part No.	Description
38124	Super Titan® 4000 25K Weld-On Receiver w/3" Sq. Ball Mount & 2-5/16" Ball, Includes 3/4" Pin & Clip
38208	Super Titan® 4000 25K Bolt-On Receiver w/3" Sq. Dual Ball Mount, 2" & 2-5/16" Balls, Includes 3/4" Pin & Clip

SUPER TITAN® 3000 - 20K

- Large 3" square receiver opening
- 20,000 lbs. weight carry capacity; 3,000 lbs. tongue weight
- Adjustable cross tube for proper height
- Two electrical plug and air brake hook up mounting locations for easy trailer attachments
- Air brake hook up locations
- 2-5/16" ball and ball mount included
- Pin & clip included
- For frame widths from 33-1/2" to 34-1/2"
- Welds to frame of vehicle

Note: 38023 is 10" from bottom of frame to bottom of receiver tube Note: 38211 is 14-1/2" from bottom of frame to bottom of receiver tube

Part No.	Description
38023	Super Titan® 3000 20K Weld-On Receiver w/3" Sq. Ball Mount & 2-5/16" Ball, Includes 3/4" Pin & Clip
38211	Super Titan® 3000 20K Weld-On Receiver w/3" Sq. Ball Mount & 2-5/16" Ball, Includes 3/4" Pin & Clip

SUPER TITAN® DUAL BALL MOUNT

- For 3" square receivers • 9" Length
- Includes 2" (17,000 lbs.) & 2-5/16" (25,000 lbs.) hitch balls

Part No.	Description
38180	Super Titan® Dual Ball Mount

SUPER TITAN® ACCESSORIES

Part No.	Description
58388	Super Titan® 3/4" Hitch Pin and Clip for 3" Square
38735	Super Titan® Reducer Sleeve from 3" to 2"

SUPER TITAN® PINTLE HOOK MOUNT

- Designed for 3" receivers
- Converts 3" receivers for use with pintle-type trailers, quickly and easily
- Provides mounting for both ball and combo pintle hooks
- Pin and clip must be ordered separately (3/4" hitch pin diameter required)

Part No.	Description
38186	Super Titan® Pintle Hook Mount, 25,000 lbs. capacity



PRO SERIES™ RECEIVER HITCHES

- Solid all-welded construction for maximum strength and safety
- Custom built according to manufacturer & model year to ensure perfect fit and top towing performance
- Computer-aided design and fatigue stress testing ensure a strong design that will withstand road abuse within specified capacities
- All hitches meet or exceed V-5 and SAE J684 standards and are inspected for quality and workmanship
- Backed by a nationwide 3-year limited warranty
- Black powder coat finish over e-coat

CLASS I RECEIVERS Part No. Series 51XXX



- 1-1/4" square receiver tube opening
- Economical Class I receiver style hitch
- Comes complete with removable drawbar, pin and clip
- Attaches to vehicle frame and/or bumper
- Black powder coat finish over e-coat

Description	Maximum Rated Capacity	
	Gross Trailer Wt.	Tongue Wt.
Weight Carrying	Up to 2,000 lbs.	Up to 200 lbs.

CLASS II RECEIVERS Part No. Series 51XXX



- 1-1/4" square receiver tube opening
- Receiver style hitch with removable drawbar
- Comes complete with removable drawbar, pin and clip
- Neat appearance and all frame attachments
- Black powder coat finish over e-coat

Description	Maximum Rated Capacity	
	Gross Trailer Wt.	Tongue Wt.
Weight Carrying	Up to 3,500 lbs.	Up to 300 lbs.

CLASS III/IV SQUARE & ROUND TUBE RECEIVERS

Part No. Series 51XXX



- 2" square receiver tube opening
- Pro Series™ receivers are designed for customers with trucks, vans and sport utility vehicles
- Designed for today's stylish sport utility vehicles, round tube receivers complement vehicle appearance
- All frame attachments
- J-Pin® ready
- Black powder coat finish over e-coat

Description	Maximum Rated Capacity	
	Gross Trailer Wt.	Tongue Wt.
Weight Carrying	Up to 6,000 lbs.	Up to 600 lbs.
Weight Distributing	Up to 10,500 lbs.	Up to 1,050 lbs.

QUICK DEFINITIONS

GTW = Gross Trailer Weight ... Weight of the trailer fully loaded

TW = Tongue Weight ... Weight exerted by the trailer coupler on the hitch ball

WC = Weight Carrying ... Tow rating capacity of a hitch without a weight distributing system

WD = Weight Distributing ... Tow rating capacity of a hitch when using a weight distributing system

MULTI-FIT MOTORHOME HITCH



5350

- 2" receiver tube accepts all standard utility ball mounts, providing ball height adjustment for level towing
- Simple three-piece construction makes assembly and installation fast and easy
- Attachment hardware included
- J-Pin® ready
- Black powder coat finish over e-coat



Part No.	Description
5350	Motorhome Hitch, Adjusts 24"-46" wide 6,000/750 lbs. WD – 5,000/500 lbs. WC

UNIVERSAL MOTORHOME HITCH



82200

- Frame brackets are adjustable



Part No.	Description
82200	Motorhome Hitch, Adjusts 31"-46" wide 6,000/750 lbs. WD – 5,000/500 lbs. WC
82201	Motorhome Hitch, Adjusts 47"-71" wide 3,500/300 lbs. WC

MOTORHOME CLASS III RECEIVER

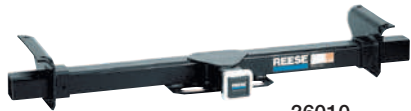

36010

- Features adjustable brackets to fit different frame widths
- Ideal for Class A & Class C motorhomes
- 2" hitch box opening



Part No.	Description
36010	5,000 WC, universal up to 46" wide

STEP BUMPER HITCHES



81378

- Do not exceed maximum GTW of bumper or hitch
- Not to be used with weight distributing systems
- May require modification or additional spacers for installation on late model pick-ups



Part No.	Description
81378	Class II Step Bumper and Receiver Hitch not for use with weight distributing equipment

CLASS III ROLL PAN RECEIVERS Part No. Series 8257X



82574

- Up to 5,000 lbs. / 500 lbs. WC - 7,500 lbs. / 750 lbs. WD
- Designed to fit late model pick-up trucks with factory close-out panels or after-market roll pans
- May require cutting of the roll pan
- May require use of a flip-down license plate bracket - not included
- Includes mounting hardware and easy to read instructions



Part No.	Year	Application	Roll Pan Style	O.E.M. or Aftermarket	Through License Plate or Below	Spare tire May Be Retained Under Vehicle Except
82574	88-00	Chevy/GMC Full Size Pickup Old Body Style	1	Aftermarket	Through	P245/75R16, P265/75R16 on short box models only
82575	99-05	Chevy/GMC New Body Style	1	Aftermarket	Through	P245/75R16 on short box models only
82571	83-04	Chevy/GMC S-10, S-15, Sonoma	2	OEM	Through	All on short box only

ROLLPAN

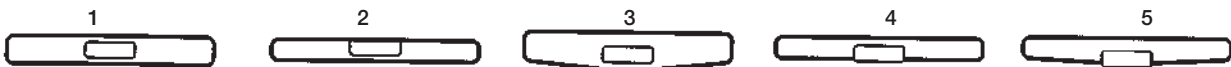



FRONT MOUNTED RECEIVERS

Part No. Series 65XXX

- Up to 9,000 lbs. Line Pull / 500 lbs.TW
- 2" square receiver tube opening
- Front mounted receivers offer a secure and useful attachment point
- All frame attachments
- J-Pin® ready
- Black powder coat finish over e-coat



6495



6980



6715



6758



5443



49802



6771

WINCH ADAPTER

Our front mounted receivers are rated for 9,000 lbs. line pull. This makes them ideal for use with winches. We offer a winch adapter that connects the winch to the receiver. They accept most models of Superwinch, Ramsey and Warn. Will not fit with S-4500 Superwinch.

Part No.	Description
6495	Winch Mounting Plate
6980	Handle Kit for #6495 Winch Mounting Plate

SPARE TIRE CARRIER

The spare tire carrier is ideal for relocating spare tires to the front of the vehicle using a front mounted receiver. It has a universal bolt pattern for mounting a variety of tire sizes.

Part No.	Description
6715	Spare Tire Carrier

WORK STEP

The work step is useful for gaining access to engine compartment, particularly with 4WD vehicles. Can also be used on rear Class III/IV receivers.

Part No.	Description
6758	Work Step

LICENSE PLATE ADAPTER

Some States and Provinces require a front license plate. The license plate adapter offers a simple solution where the front hitch interferes with the plate.

Part No.	Description
5443	License Plate Adapter

FOLD DOWN LICENSE PLATE HOLDER

Part No.	Description
49802	Fold Down License Plate Holder

RECEIVER TUBE SKID SHIELD

Off road enthusiasts know what this one is for. It is recommended for use with receivers that are mounted below the bumper.

Part No.	Description
6771	Receiver Tube Skid Shield

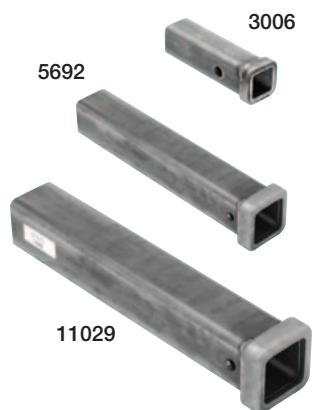

COMBO BARS - UNPAINTED

Designed for use in fabricating undercar receiver hitches when a receiver is not available.

- Made of cold formed structural tubing
- Sized and punched to fit all common weight distributing hitch ball mounts or utility ball mounts

Part No.	Length	Dia.	Ring
2850	6"	2" x 2"	Standard
11081	8"	2" x 2"	Standard
2851	12"	2" x 2"	Standard
2898	18"	2" x 2"	Standard
2852	24"	2" x 2"	Standard
2853	36"	2" x 2"	Standard
2854	48"	2" x 2"	Standard
3006	6"	1-1/4" x 1-1/4"	Standard
5691	12"	2" x 2"	Cast
5692	18"	2" x 2"	Cast
11029	18"	2-1/2" x 2-1/2"	Cast



COMBO BARS - PAINTED

Part No.	Length	Dia.	Ring
80806	6"	2" x 2"	Standard
80812	12"	2" x 2"	Standard
80818	18"	2" x 2"	Standard

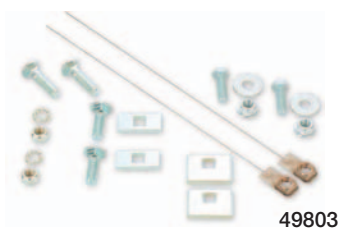

FASTENERS

- Bulk Packaged

Part No.	Description
1591	Fastener Assortment (Hex bolts, blocks, etc...)
49803	Fastener Assortment (Carriage bolts, blocks, etc...)

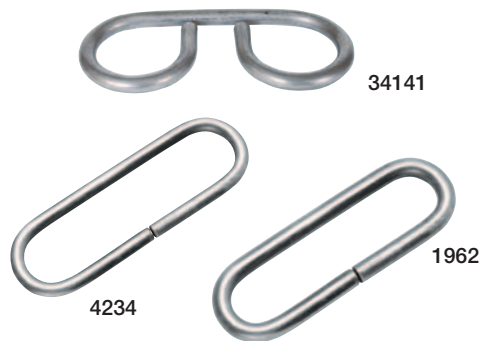

SAFETY CHAIN LOOPS

Part No.	Description
4234	2,000 lbs. Class I Safety Chain Loop
1962	5,000 lbs. Class II/III Safety Chain Loop
34141	10,000 lbs. Class IV Safety Chain Loop