

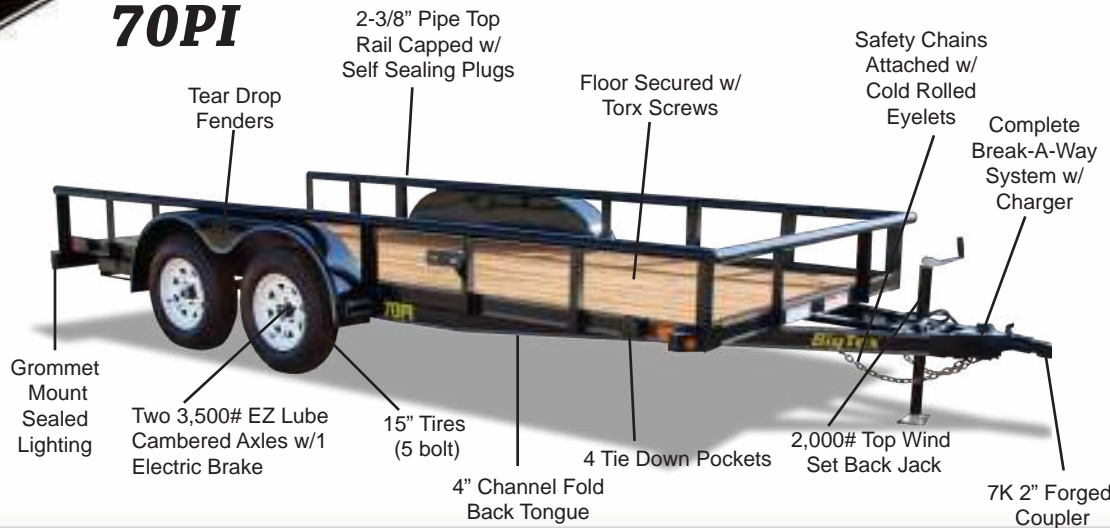

TANDEM AXLE

www.bigtextrailers.com

70PI



- **70PI comes in 77" or 83" width and in lengths of 14', 16', 18' and 20'**
- **Approximate Carrying Capacity ranges from 4,750# - 5,300# depending on length**

Wide width provides versatility to haul just about anything you need for heavy lawn and garden use, large ATV's, big quads, side-by-sides and medium range tractors.

40SP



- **Tandem Axle in 77" width and standard lengths of 14' and 16'**
- **Carrying Capacity ranges from 2,500# to 2,700#, depending on length**
- **2" A-Frame Coupler • 15" Tires (5 bolt) • 2" Angle Iron Top Rail**

Econo style trailer comes with angle iron top rail and tie down loops to help secure load. Great for hauling 4-wheelers, small tractors and lawn and garden equipment.

45SS



- **77" x 16' Tandem Axle • 3,050# Approximate Carrying Capacity**
- **2" A-Frame Coupler • 15" Tires (5 bolt)**
- **2-3/8" Pipe Top Rail**

The 45SS is an econo style trailer with a pipe top rail that is perfect for and lawn and garden use. Also great for hauling 4-wheelers, side-by-sides, and small tractors.

45LA



- **60" width and in lengths of 10', 12' and 14' • Approximate Carrying Capacity ranges from 3,100# - 3,350# depending on length**
- **2" A-Frame Coupler • 15" Tires (5 bolt) • 3" Angle Top Rail**

Medium duty home and garden trailer. Angle top rail and tie down loops make for a secure load. Great for 4-wheelers and small tractors. Shown with optional rampgate. Narrow width for easy storage.

50LA



- **77" width and in lengths of 10', 12', 14', 16' and 18' • Approximate Carrying Capacity ranges from 3,400# - 3,850# depending on length**
- **2" A-Frame Coupler • 15" Tires (5 bolt)**
- **3" Angle Top Rail**

The different length options for the 50LA make this a versatile trailer to fit almost any need. Great for hauling multiple 4-wheelers, side-by-sides, big quads and small tractors.

60CH



- 83" width and in lengths of 14' and 16'
- Approximate Carrying Capacity ranges from 4,300# - 4,350# depending on length
- 2" A-Frame Coupler
- 15" Tires (5 bolt)

An econo style car hauler, the 60CH is great for autos, small tractors, ATV's and side-by-sides. Tie-down pockets down each side allow for multiple places to secure cargo.

60SP



- 77" width and in lengths of 14' and 16'
- Approximate Carrying Capacity ranges from 4,350# - 4,550# depending on length
- 2" A-Frame Coupler
- 15" Tires (5 bolt)
- 2-3/8" Pipe Square Back Top Rail

The 60SP is sturdy, versatile and economical. Perfect for small tractors, ATV's, side-by-sides and general lawn and garden applications.

70CH



- 83" width and in lengths of 12', 14', 16', 18' and 20'
- Approximate Carrying Capacity ranges from 4,500# - 5,300# depending on length
- 7K 2" Forged Coupler
- 15" Tires (5 bolt)
- Front Stop Rail
- Tear Drop Fenders

With a fold-back tongue and teardrop fenders, the 70CH is built to work. This versatile trailer can be used for autos, small tractors, ATV's, side-by-sides and numerous other applications.

70DM



- 83" width and in lengths of 18' and 20'
- Approximate Carrying Capacity ranges from 4,600# - 4,750# depending on length
- 7K 2" Forged Coupler
- 15" Tires (5 bolt)
- Chamfered Front Stop Rail
- Chrome Wheels

The 70DM is the premier car hauler in the Big Tex line. Chrome wheels, steel floor, and diamond plate rear slide out ramps make the 70DM easy to use as well as easy to look at. The box tubing frame gives the trailer added strength and durability.

70TV



- 83" width and in lengths of 12', 14' and 16'
- Approximate Carrying Capacity ranges from 4,900# - 5,150# depending on length
- 7K 2" Forged Coupler
- 15" Tires (5 bolt)
- V-Crimped Steel Panel Sides
- 2-3/8" Pipe Top Rail

Wide width and higher v-crimped steel sides provide versatility to haul just about anything you need and help to protect your cargo. Perfect for heavy lawn and garden use, as well as heavy duty landscaping.

70LR



- 83" width and in lengths of 14' and 16'
- Approximate Carrying Capacity ranges from 4,500# - 5,000# depending on length
- 7K 2" Forged Coupler
- 15" Tires (5 bolt)
- Expanded Metal Sides
- Lockable Landscape Box

The 70LR with its tool holders, expanded metal sides and lockable landscape box make this the "perfect" landscape trailer for the professional landscaper or gardener.

10PI / 12PI



- 10PI comes in 83" width and in lengths of 14', 16' and 20'
- 12PI comes in 83" width and in lengths of 16', 18' and 20'
- 10PI Approximate Carrying Capacity ranges from 7,000# - 8,000# depending on length & 12PI ranges from 9,300# - 9,500# depending on length
- 2-5/16" Forged Coupler
- 10PI has 15" Tires (6 bolt) & 12PI has 16" Tires (8 bolt)

The 10PI & 12PI are perfect for hauling light to medium duty equipment and small tractors. Slide in ramps allow for easy loading and unloading of equipment.