

STEP 8 – TIGHTEN HARDWARE

1. Tighten the center section to cross member bolts to 80 ft pounds. 2. Check to ensure the assembled center section is square with the frame. 3. Tighten the 3/4" side plate bolts to 120 ft pounds. 4. Tighten the 1/2" side plate bolts to 80 ft pounds. 5. Tighten the side plate to angle bolts to 80 ft pounds.

STEP 9 – INSTALL LATCH PIN RELEASE HANDLE

WARNING: LATCH PIN WILL NOT FUNCTION PROPERLY IF HANDLE IS NOT INSTALLED CORRECTLY.

Install the handle from underneath the truck by inserting it through the slot in the end of the center section toward the driver's side rear tire as shown. Attach the handle to the latch pin as shown with the handle on the "cab side" of the square tab welded to the pin.

The head of the bolt must be on the handle side, and the lock nut must be on the tab side. The tab is welded to the pin in an offset position so that the handle will be lined up over the center of the pin. If the handle is fastened to the other side of the tab, the handle will not function properly. When installed correctly the latch pin may be disengaged from the ball by pulling on the handle from the driver's side wheel well and rotating the handle clockwise.

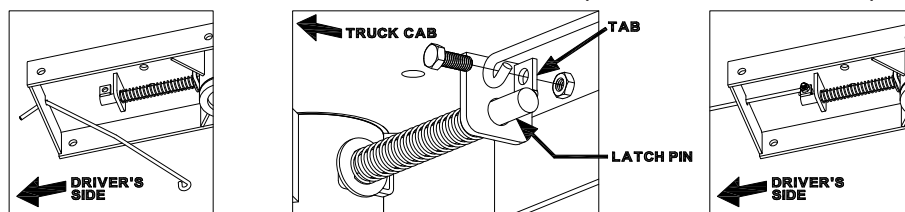

STEP 10 – INSTALL SAFETY CHAIN U-BOLTS

To install the safety chain U-bolts, it is necessary to drill four 1/2" holes through the truck bed floor. Drill the holes from beneath the truck, through the two holes located on each side and closest to the round receiver tube in the center section. This will locate the safety chain U-bolt in the lowest point of the floor corrugation. After you drill the four holes, clean the burrs from around the holes in the top of the bed, then drop a U-bolt through each pair of holes. Place a spring and lock nut on each of the four legs. Tighten the nuts until flush with the bottom of the U-bolts.

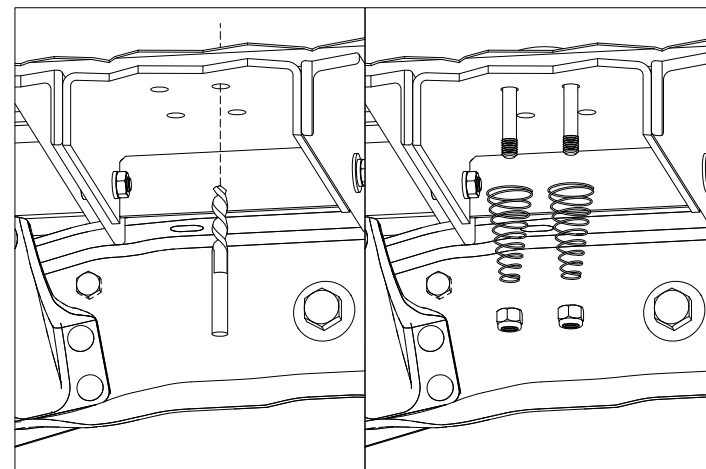

STEP 11 – RE-ATTACH EXHAUST

In pickups equipped with a diesel engine, the exhaust may have to be lowered to allow clearance for the Turnoverball™ Hitch. See Diagrams 11.1 and 11.2.

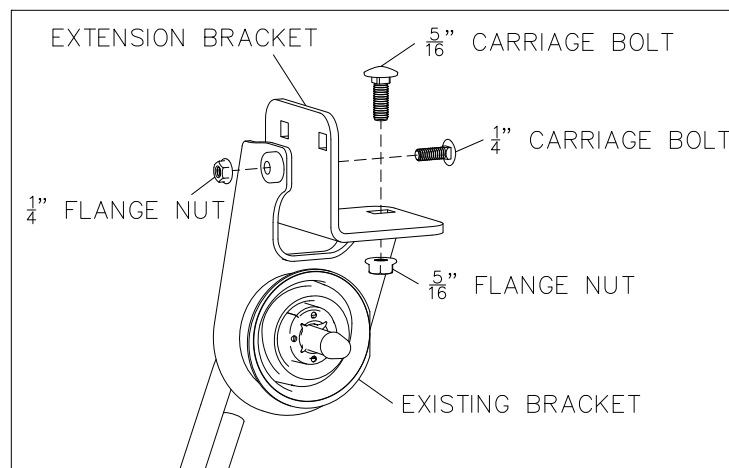

Diagram 11.1. Attach the supplied extension bracket to the existing tail pipe bracket.

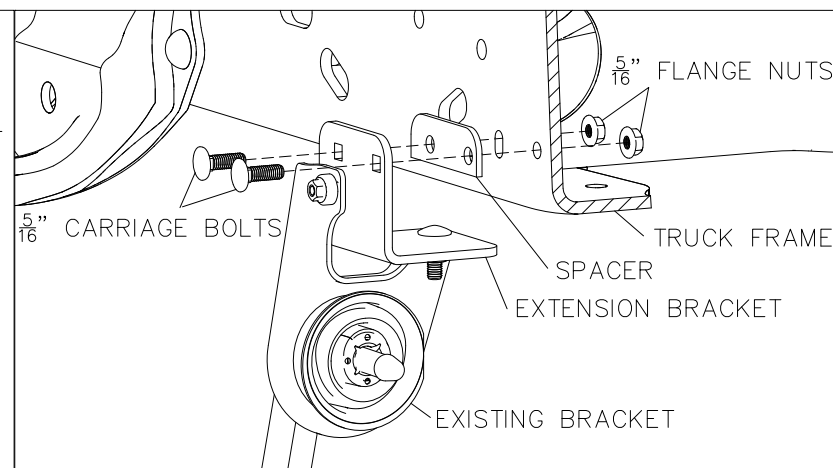

Diagram 11.2. Attach the supplied extension bracket to the frame, using the same hole used by the factory bracket and the hole directly right of it. Not all truck models will have the hole directly to the right. In this case, attaching the bracket with one bolt is sufficient.

STEP 12 – RE-ENGAGE LATCH PIN HANDLE

Retract the latch pin by pulling the handle all the way out until it stops and then rotate it clockwise. Place the 2-5/16" Ball in the hitch receiver. Engage the latch pin by rotating the handle counterclockwise. Be certain the latch pin passes through the holes in the 2-5/16" Ball and fully engages through the hitch receiver. Remove and grease the square base of the 2-5/16" Ball.

STEP 13 – Reinstall the spare tire heat shield and spare tire.



B&W Trailer Hitches
1216 HWY 224 / PO Box 186
Humboldt, KS 66748
P:620.473.3664
F:620.473.3766

Attention:

If you intend to use a Companion 5th Wheel RV Hitch in a **2011 Ford** Truck, please call us at 800-248-6564 for a foot pad kit that fills voids in the truck bed rib pattern. Using the Companion on a **2011 Ford** without the supplemental kit could result in damage to the bed.

NOTE: *We recommend reading instructions before beginning the installation.*

WARNING: *The tow vehicle's towing capacities should under NO circumstances be exceeded.*

Turnoverball™ Gooseneck Hitch Installation Instructions

Model 1111

Ford Super Duty 2011-2012
3/4 & 1 Ton, Short & Long Bed
F-450 w/Factory Installed Bed

Call or Email us for Installation Support
800.248.6564 hitches@turnoverball.com

www.turnoverball.com

- Hardware Kit**
- 2 ea. - 3/4" X 2 1/2" Bolts
 - 14 ea. - 1/2" X 1 1/2" Bolts
 - 3 ea. - 5/16" X 1 Carriage Bolts
 - 1 ea. - 1/4" X 3/4" Carriage Bolt
 - 1 ea. - 3/4" Flat Washer
 - 1 ea. - 3/4" Rectangular Washer
 - 14 ea. - 1/2" Flat Washers
 - 2 ea. - 3/4" Lock Washers
 - 14 ea. - 1/2" Lock Washers
 - 2 ea. - 3/4" Nuts
 - 14 ea. - 1/2" Nuts
 - 3 ea. - 5/16" Flange Nut
 - 1 ea. - 1/4" Flange Nut
 - 2 ea. - Pipe Spacers
 - 1 ea. - Exhaust Bracket
 - 1 ea. - Exhaust Spacer
 - 1 ea. - Sensor control module relocation bracket.

- Safety Chain Kit**
- 2 ea. - 1/2" U-Bolts
 - 4 ea. - 1/2" Lock Nuts
 - 4 ea. - Springs

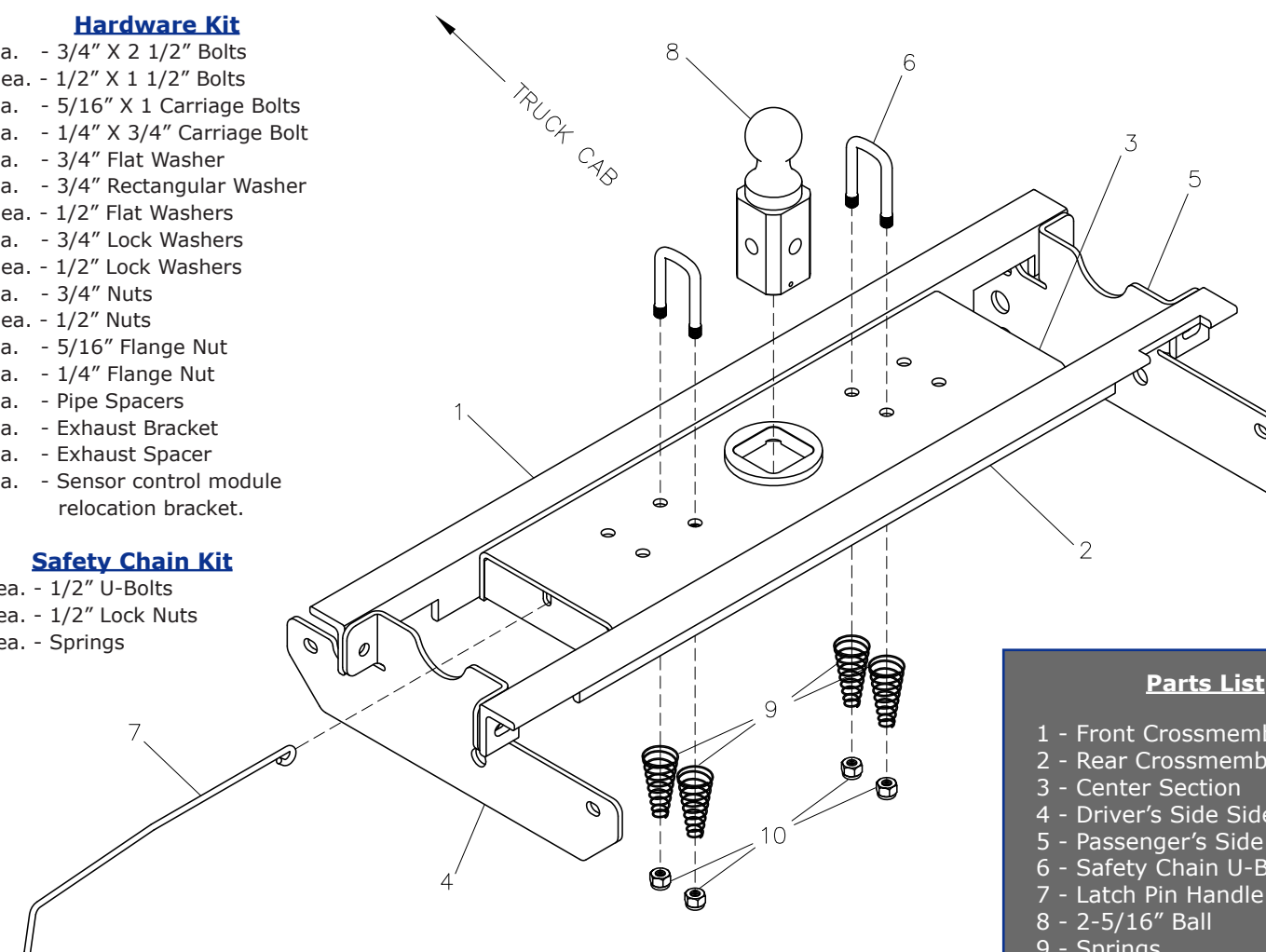

Parts List

- 1 - Front Crossmember
- 2 - Rear Crossmember
- 3 - Center Section
- 4 - Driver's Side Sideplate
- 5 - Passenger's Side Sideplate
- 6 - Safety Chain U-Bolts
- 7 - Latch Pin Handle
- 8 - 2-5/16" Ball
- 9 - Springs
- 10 - 1/2" Lock nuts

BEFORE INSTALLING- OVERHEAD LIFTING DEVICE

An overhead-lifting device, such as chain falls, engine hoist, or cable come-a-long, can be used to lift the center section of the hitch in place. Lower a loop of rope or chain through the 4" hole in the truck bed floor and attach it to the latch pin in the round hitch receiver tube in the center section. Use the lifting device to raise the center section until the round hitch receiver tube that protrudes from the center section fits in the 4" hole in the truck bed floor. Maintaining upward pressure may facilitate fastening the crossmember to the center section, especially if the truck bed floor has been distorted downward from heavy use. If you use an overhead-lifting device, it should be disconnected before squaring the center section across the frame, installing the sideplates and torquing fasteners.

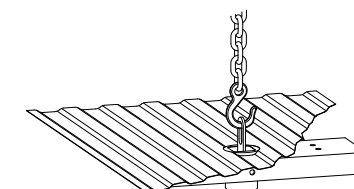

****** HAND TIGHTEN ALL HARDWARE IN STEPS 6 AND 7 ******

WARNING

Most trucks have FUEL LINES and/or BRAKE LINES and/or ELECTRICAL WIRES located along the frame rails where B&W Turnoverball™ hitches install. Carefully examine the location of fuel lines, brake lines and electrical wires BEFORE INSTALLATION. Be certain you will not damage fuel lines, brake lines or electrical wires when positioning hitch components, drilling holes, tightening fasteners, and lifting and lowering the truck bed. The fuel tank vent, located on top of the gas tank, can be easily damaged during the installation of the hitch components. Care must be taken when positioning the front crossmember and center section components.

WARNING

On Short bed trucks, BEFORE INSTALLING THIS HITCH, check for adequate turning clearance between the front of all of your trailers and the truck cab.

WARNING

DO NOT invert the ball in the socket when carrying heavy loads on 2 wheel drive trucks. The ball may hit the top of the differential. Remove the ball from the socket before loading. A plug for the socket is available from B&W.

INSTALLATION INSTRUCTIONS

BALL LOCATION: F250 AND F350 SHORT AND LONG BED SUPER DUTY'S & F450 with Factory Installed Bed = **46-1/8"**

REMOVE SPARE TIRE BEFORE INSTALLING HITCH.

******SAFETY NOTICE******

if a spare tire heat shield is present, we recommend that it be removed to avoid injury.

STEP 1 – MARKING AND CUTTING 4-INCH-HOLE IN TRUCK BED

Begin by measuring for the correct hole location in the truck bed floor. Measure from the tail gate end of the truck bed floor by hooking a tape measure over the end of the truck box and mark the floor at 46-1/8". Next find the center point between the wheel wells, where these marks intersect with the first measurement will be the center point of your four inch hole. This location is critical to the correct installation of the B&W Turnoverball™, so measure, mark and saw carefully. Make a four-inch hole at this location. B&W recommends using a four inch hole saw, however the hole can be cut by other means. If your truck has a spray-in bed liner, you will need to take into account when you are measuring to add the thickness of the applied liner that has been sprayed over the end of the bed. If your truck has a Drop-in plastic bed liner, you may saw through both, but it is more difficult to accurately locate the midpoint between the fender wheel wells. Be sure that the bed liner does not move when sawing the hole. Once you have the four-inch hole in the bed, use a de-burring tool or a die grinder and carefully remove the burr from the under side of the bed around the hole.

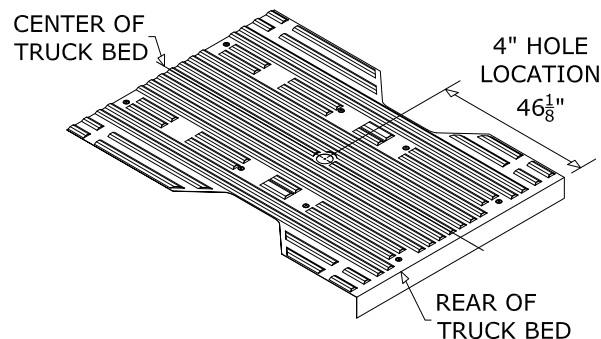

STEP 2 – HEAT SHIELD REMOVAL

Remove the heat shield located above the rear axle under the truck bed.

STEP 3 – EXHAUST BRACKET REMOVAL

On trucks equipped with a diesel engine the tail pipe will need to be lowered. Un-attach the tail pipe bracket just behind the rear tire on the passenger side. Installation on gasoline equipped trucks may be easier if exhaust is detached. The bracket will be reattached later.

STEP 4 – BED FLANGE MODIFICATION

Some models of trucks will allow the crossmembers to slide between the frame and bed without modification. If this is not possible a small notch needs to be made in the flange on the driver's side of the truck. (see diagram)

Locate the front truck bed cross member in the wheel well. Measure from the back of the cross member and make a mark at 1 1/2". This will be the center point for the notch that is needed. Mark and cut a 7/8" wide by 3/8" tall notch.

BED FLOOR FLANGE IN DRIVER'S SIDE WHEEL WELL

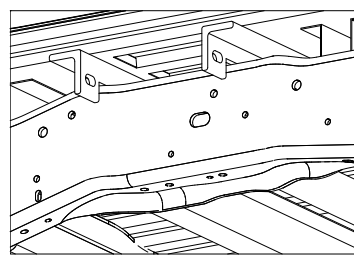
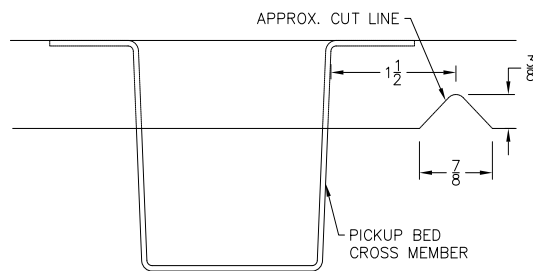

figure 5.1, outside of driver side frame

STEP 5 – CROSS MEMBER INSTALLATION

The 1111 mounting kit is supplied with two angle crossmembers. The rear crossmember has three notches and will be installed first. Slide the rear crossmember between the frame and bed on the driver's side. If necessary use the notch cut into the bed flange in step 4. Make certain the leg of the angle with the oval holes is facing toward the cab. After sliding the angle in about half way it may need to be guided onto the other frame from the underside the truck. At this point the angle should span between both frame rails and in front of the shock bracket on the passenger side. Next using the notch over the shock bracket for clearance, roll the angle iron over the bracket while sliding it toward the rear. **It is important to hold the driver's side of the crossmember upward against the bed floor and forward against the bed crossmember.** Continue to slide it back until it is about four inches behind the four inch hole that has been drilled in the bed. Next install the front angle in the same manor except for the leg of the angle with the oval holes should face the rear of the truck during installation. Slide it rearward just behind the shock bracket and leave until needed for installation. When installed correctly the two angle legs with the holes should be facing each other. (see figure 5.1.)

Notice: In trucks with gasoline engines un-attach the fuel vent line bracket on the inside of the driver side frame, before installing side plates. Once installation is completed, replace fuel vent line bracket.



STEP 6 – INSTALL THE CENTER SECTION

Raise the center section into position between the cross members from beneath the truck, with the latch pin release handle on the drivers side. While holding down on the exhaust, position the center section over the exhaust first then over the brake line bracket. A lifting device, as described on page 2 will help. (see figure 6.1) The round hitch receiver that protrudes from the top of the center section must fit through the hole in the truck bed floor. Slide the angles against the center section (an adjustable wrench can be used to stand the angles up if needed) and bolt together using six 1/2" x 1 1/2" bolts. Place the bolts with a flat washer through the slots in the cross member and through the holes in the center section and add a 1/2" lock washer and nut. Next, bolt the sideplates to the angle cross members using a 1/2" x 1 1/2" bolt through the sideplate, through the angle and add a 1/2" flat washer, lock washer and nut.

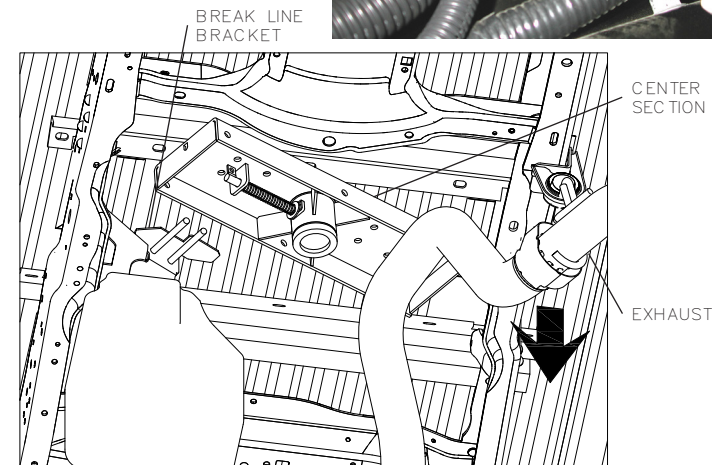

figure 6.1, View from under truck bed looking up at hitch

STEP 7 – INSTALL SIDE PLATES

Install the side plates on the outside of the frame by passing a 3/4" hex bolt and washer from the inside of the frame to the outside. (The driver side washer is non-standard, see figure 7.1). Place a spacer ring over the 3/4" bolt on the outside of the frame. Next, carefully place a side plate over the 3/4" bolt and secure in place with a lock washer and nut. Next, install 1/2" bolts in the front and rear of the side plate starting with a 1/2" bolt on the inside of the frame and a flat washer, lock washer, and nut on the outside of the frame (see figure 7.2 and 7.3). Repeat side plate installation for both sides of the truck frame. If passenger side installation is blocked, see notice below.

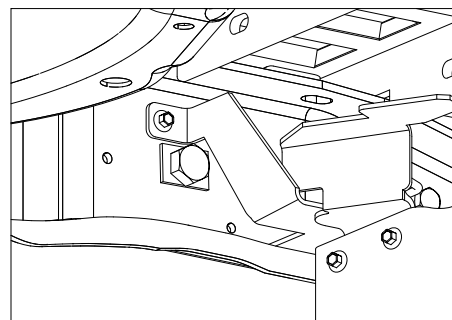

figure 7.1, inside of driver side frame

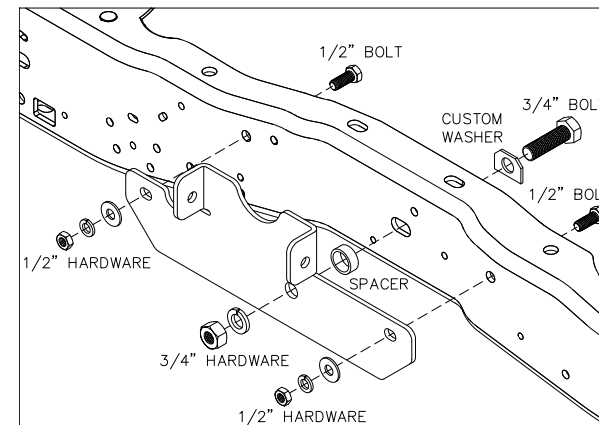

figure 7.2, exploded diagram of driver sideplate plate

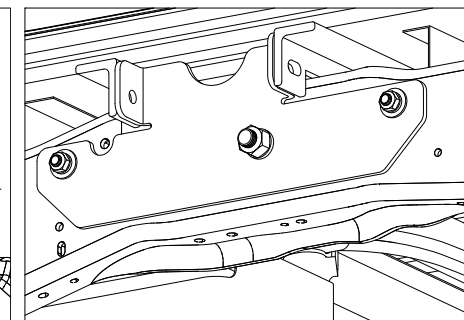

figure 7.3, outside of driver side frame

****NOTICE**** - On certain models of the Diesel Ford Super Duty a sensor control module is located over a hole needed to install the passenger side plate of the B&W hitch. A bracket has been supplied to relocate the module so the side plate can be installed. To begin, locate the module on the inside of the passenger frame rail (see figure 7.4). Once located, remove the two bolts holding the module to the frame. Caution, do not remove heat shielding from wiring harness. Wiring must remain as close to its original location as possible to protect it from the heat of the exhaust system. With the 3/4" bolt through the bracket, (see figure 7.5) attach the module to the bracket with the two factory bolts (see figure 7.6). Insert 3/4" bolt through oval slot in the frame and continue with sideplate installation. See figure 7.7 for relocated module in its final position.

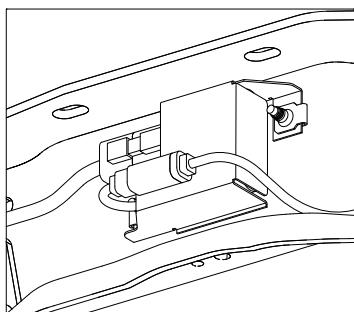

figure 7.4, inside of the passenger side frame.

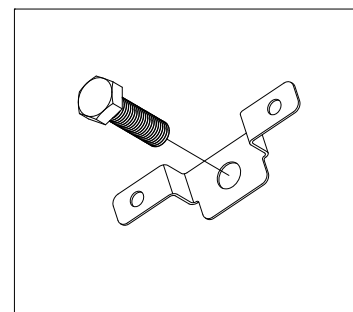

figure 7.5, supplied bracket and 3/4" bolt.

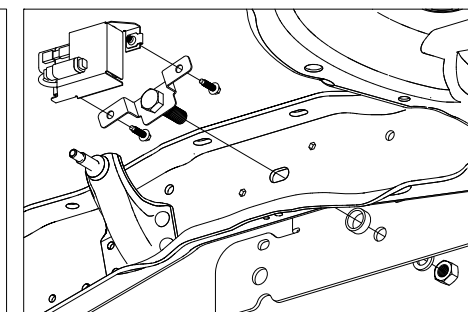

figure 7.6, inside of the passenger side frame.

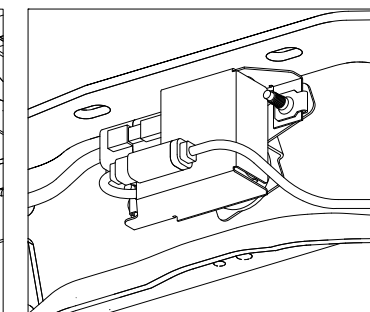

Figure 7.7, installed bracket and module